

WANDERZIRKUS »RAIMONDI«



»RAIMONDI« TRAVELLING CIRCUS

CIRQUE AMBULANT »RAIMONDI«

CIRCUS OP DE DOORREIS »RAIMONDI«

Art. Nr. 130990

D

Vor Beginn des Bastelns sollten Sie sich mit den Spritzlingen und der Anleitung vertraut machen. Sollte es einmal vorkommen, dass ein Teil im Bausatz fehlt, kreuzen Sie bitte das fehlende Teil in der Anleitung an und schicken Sie diese bitte an Fa. Gebr. FALLER GmbH, Abt. Kundendienst, kundendienst@faller.de, Kreuzstraße 9, 78148 Gütenbach. Sie erhalten dann umgehend Ersatz. Es kann vorkommen, dass bei einem Bausatz Einzelteile übrig sind.

GB

Before beginning with the assembly please familiarize yourself with the parts and read the instructions carefully. In case of missing parts please indicate these on the instructions leaflet with a circle and return the leaflet to Gebr. FALLER GmbH, kundendienst@faller.de, Kreuzstraße 9, D-78148 Gütenbach, Germany. You will receive the replacement by return. It may happen in a kit that some parts are not required.

F

Avant de commencer le montage de votre maquette bien lire la notice et repérer les grappes. Si une pièce manque dans une boîte, cochez la pièce correspondante sur la notice et renvoyez-la-nous à Gebr. FALLER GmbH, kundendienst@faller.de, Kreuzstraße 9, D-78148 Gütenbach (R.F.A.). Nous vous ferons parvenir la pièce par retour. Dans certains kits, il est possible que certaines pièces ne soient pas utilisées.

NL

Vóór het bouwen zou men de gietstukken en de handleiding moeten bestuderen. Indien onverhoopt een onderdeel aan het bouwpakket ontbreekt, gelieve men het ontbrekende deel in de handleiding aan te kruisen en deze te zenden aan Gebr. FALLER GmbH, kundendienst@faller.de, Kreuzstraße 9, D-78148 Gütenbach. U ontvangt dan omgaand en gratis het ontbrekende onderdeel. Het kan voorkomen dat u bij bepaalde bouwdozen onderdelen overhoudt.

Für den Zusammenbau des Modells empfehlen wir folgende FALLER-Artikel (sind nicht im Bausatz enthalten):

For the assembly of the kit we recommend following FALLER products (not included in the kit):

Pour l'assemblage du modèle, nous vous recommandons les articles FALLER suivants (non inclus dans le kit):

Om dit model te bouwen adviseren wij de volgende FALLER producten (maken geen deel uit van deze bouwset):



Art. Nr. 170492
FALLER-EXPERT

Flüssigkleber in Plastikflasche mit Spezialkanüle für feinste Klebstoffdosierung.

Liquid cement in plastic bottle with canule for very fine dosage.

Colle liquide en bouteille plastique avec bec verseur pour un dosage précis.

Vloeibare lijm in plastic-flescon met doseerbuisje om nauwkeurig te lijmen.



Art. Nr. 170688
SPEZIAL-SEITENSCHNEIDER

zum gratfreien Abtrennen von feinsten Spritzteilen. Nur für Polystyrol geeignet.

Special side cutter for cutting off ultra-fine moulded parts without burrs. Only suitable for polystyrene.

Pince coupants spéciale pour couper sans bavure les pièces miniatures moulées par injection. Convient uniquement au polystyrène.

Speciale zijknijplang voor het burraansloos afknippen van de fijnste gietstukdelen. Alleen geschikt voor polystyrol.



| | | | | | | |
|-----------------|-------------|---------|----------|---------|----------|-----------|
| Inhalt | Spritzlinge | 1 A 1 x | 2 AB 1 x | 4 1 x | 7 B 1 x | 21 C 1 x |
| Contents | Sprues | 1 B 1 x | 3 1 x | 4 B 1 x | 8 1 x | 41 B 1 x |
| Contenu | Moulages | 1 B 1 x | 3 1 x | 5 A 1 x | 8 B 1 x | 570 S 2 x |
| Inhoud | Gietstukken | 2 A 1 x | 3 AB 1 x | 5 B 1 x | 21 B 5 x | |

Sa. Nr. 130 990 1

2

3/1

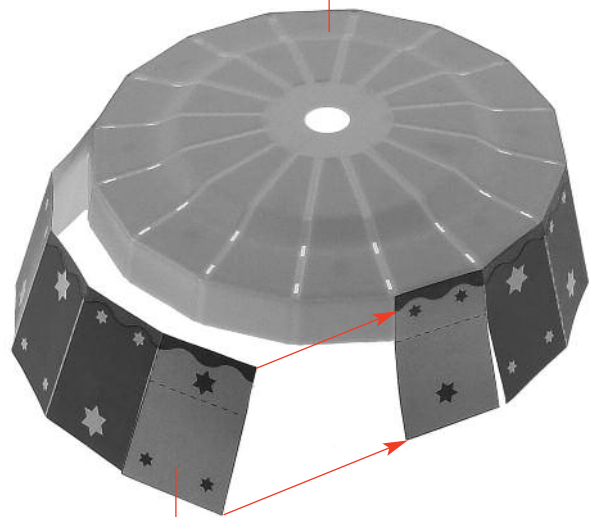

Papiermaske
 Papermask
 Masque
 Masker **M1**

Mit Alleskleber kleben
 Use all-purpose glue
 Utiliser de la colle universelle
 Met een universele lijm lijmen

A

8 x
200 mm

| | | | | | |
|---------|--------|----------|-------|--------|--------|
| Inhalt | Tüte | Contents | bag | silver | silver |
| Contenu | sachet | Inhoud | zakje | argent | zilver |

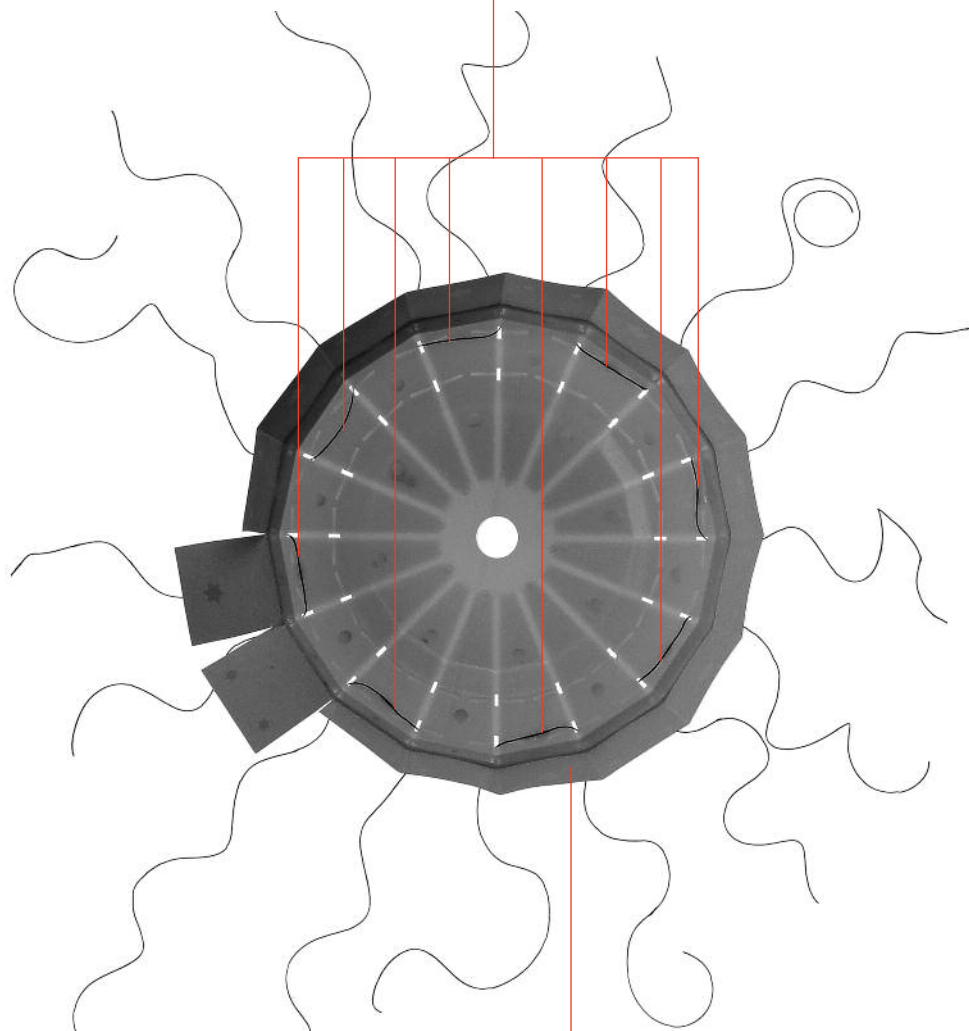

B

A

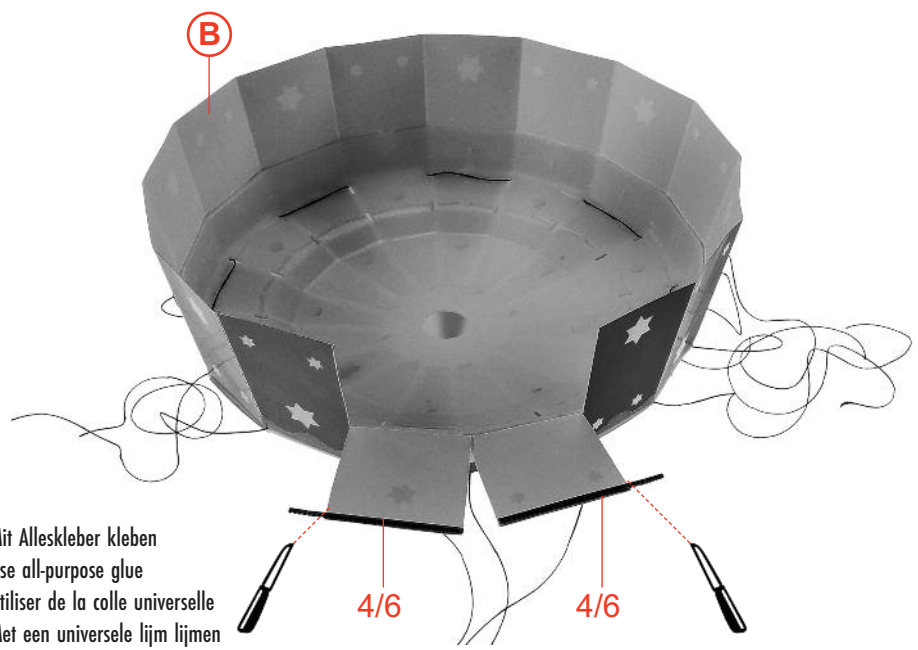

Mit Alleskleber kleben
 Use all-purpose glue
 Utiliser de la colle universelle
 Met een universele lijm lijmen

C

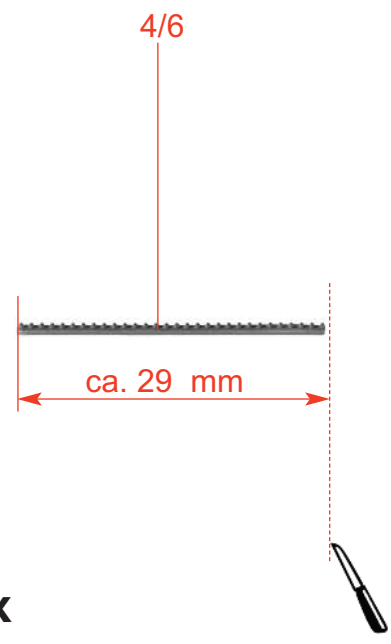

D 4 x

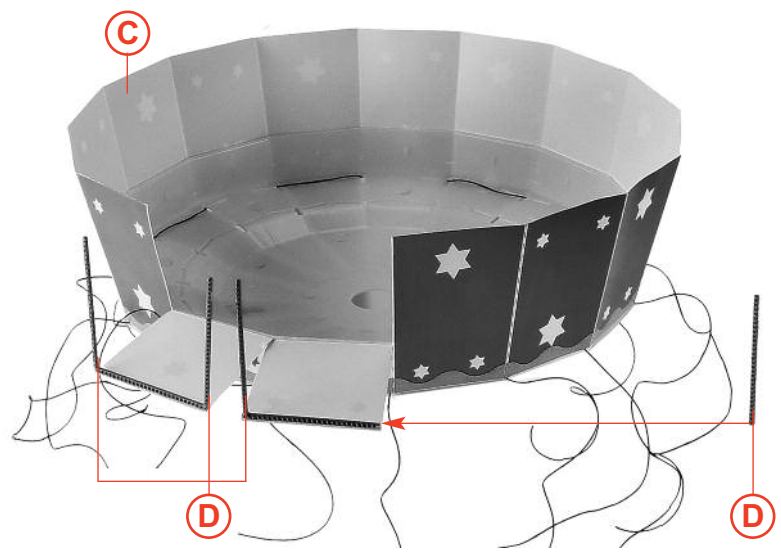

E

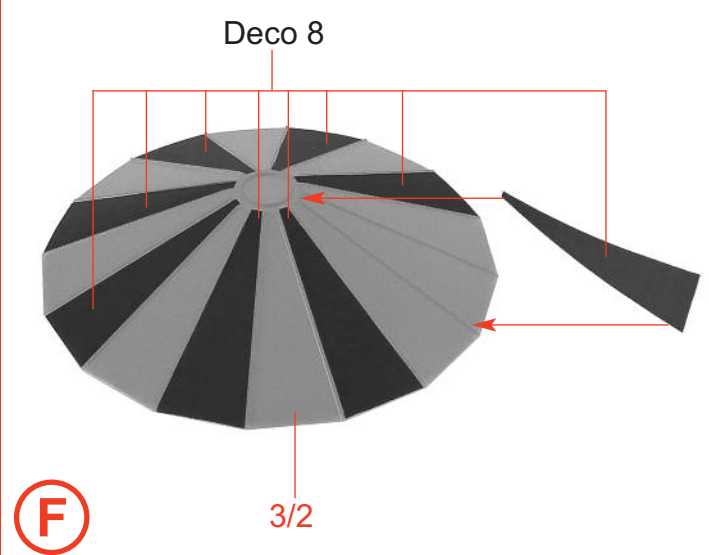

F 3/2

4

Deco 4
+
Deco 5

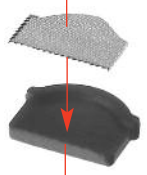

G 8 x 5/5 B

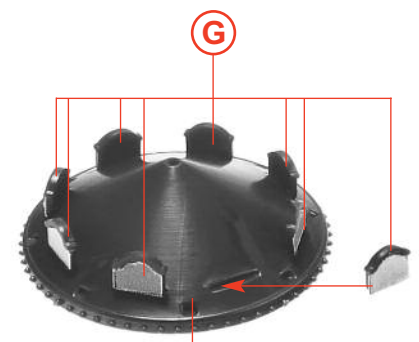

H 5/6 B

Deco 6
+
Deco 7

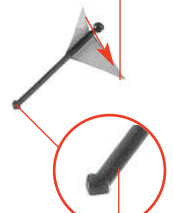

I 8 x 5/4 A

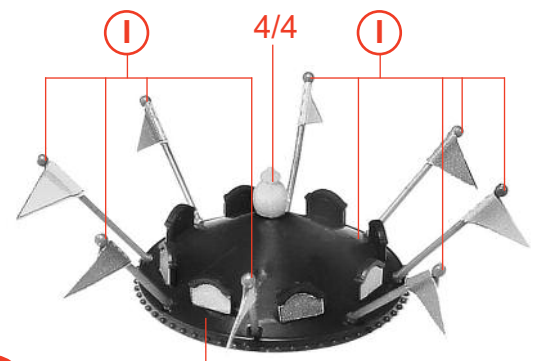

J **H** 4/4

F

E

K

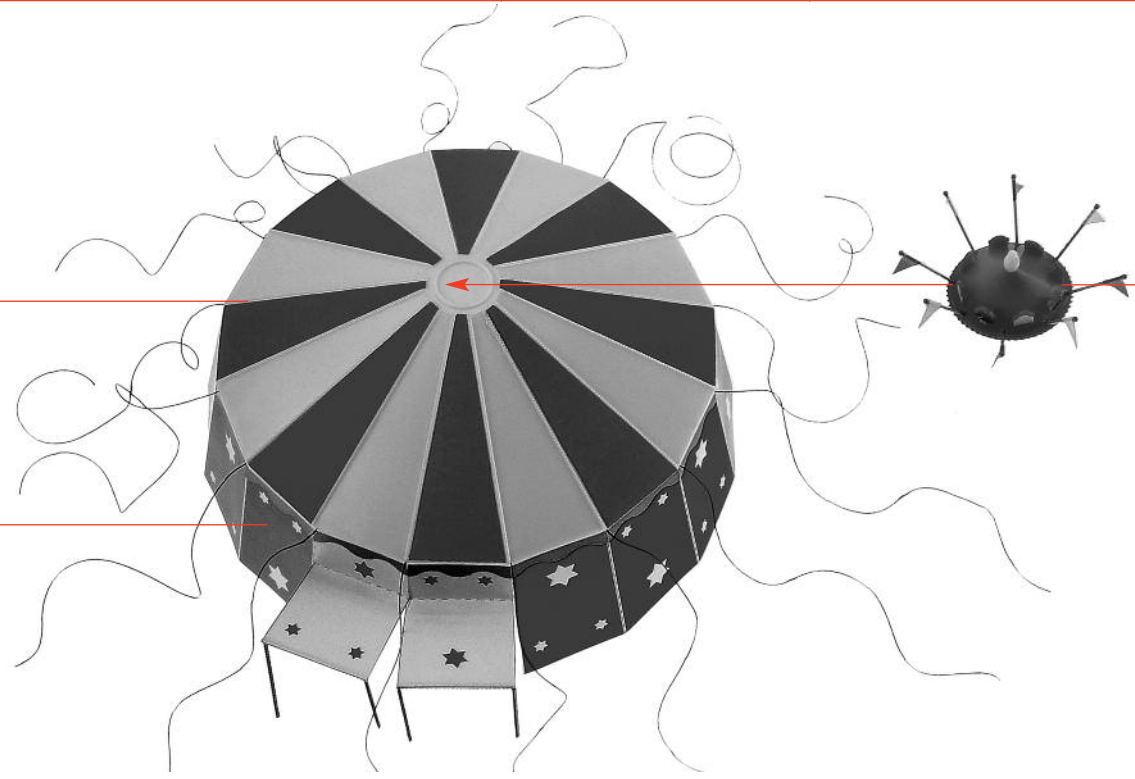

J

8 x
100 mm

| | | | | | |
|---------|--------|----------|-------|--------|--------|
| Inhalt | Tüte | Contents | bag | silber | silver |
| Contenu | sachet | Inhoud | zakje | argent | zilver |

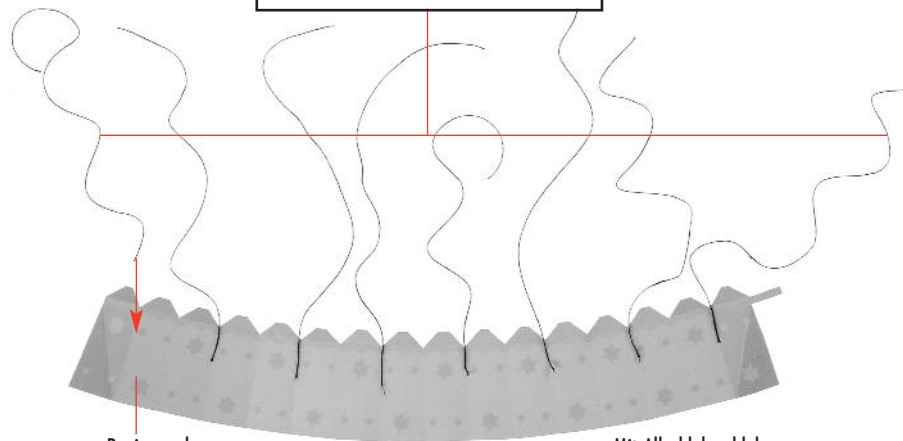

Papiermaske
Papermask
Masque
Masker **M2**

Mit Alleskleber kleben
Use all-purpose glue
Utiliser de la colle universelle
Met een universele lijm lijmen

L

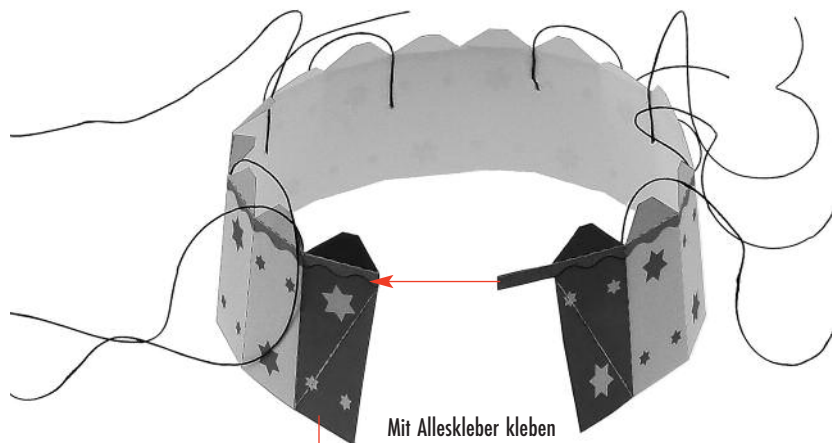

Mit Alleskleber kleben
Use all-purpose glue
Utiliser de la colle universelle
Met een universele lijm lijmen

M

L

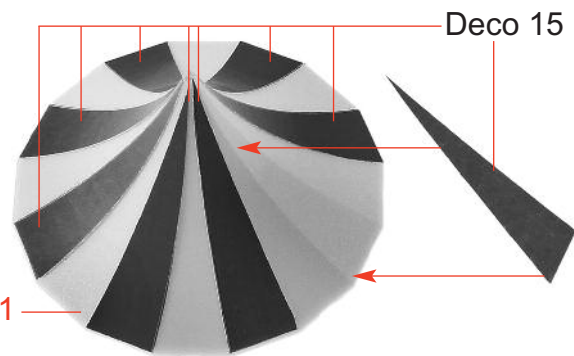

N

4/1

Deco 15

5

N

Mit Alleskleber kleben
Use all-purpose glue
Utiliser de la colle universelle
Met een universele lijm lijmen

M

O

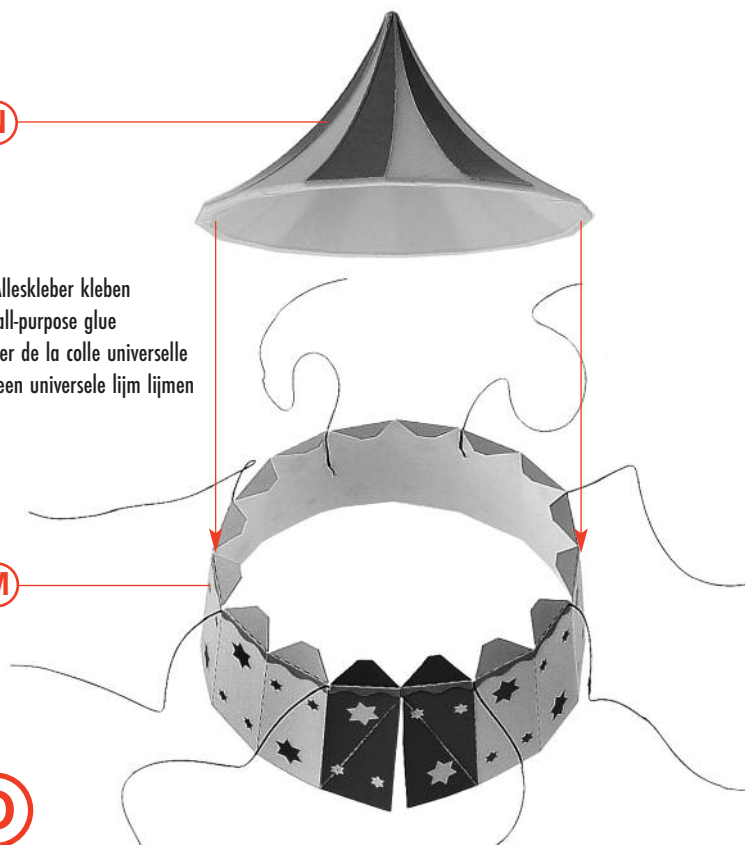

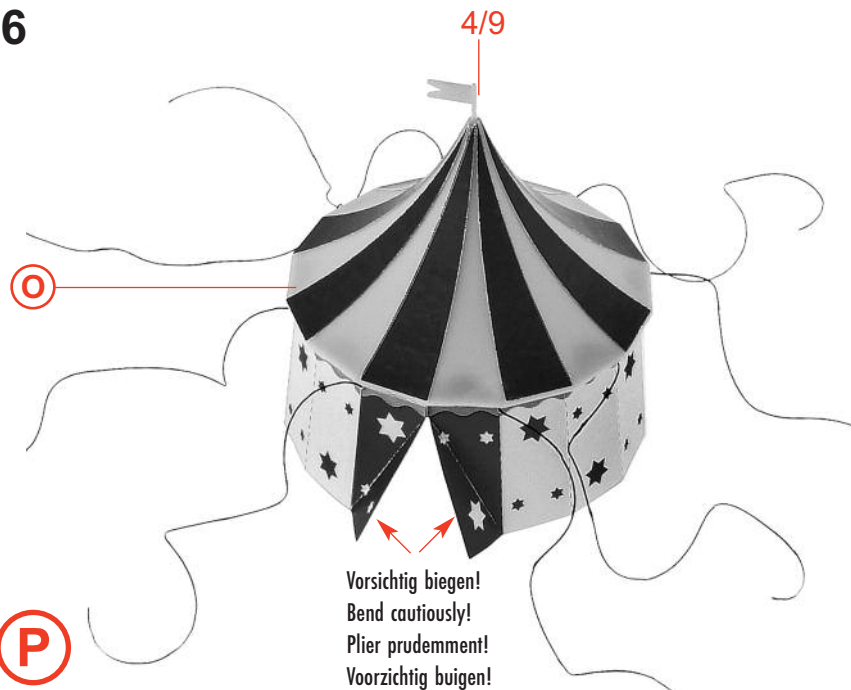
6**P**

Mit Alleskleber kleben
Use all-purpose glue
Utiliser de la colle universelle
Met een universele lijm lijmen

Deco 3

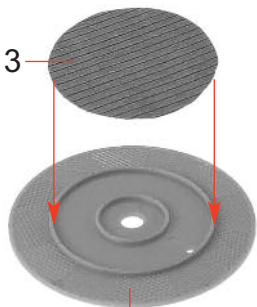

3/3

Q

Deco 19

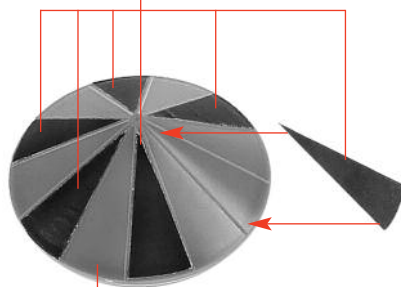

3/7

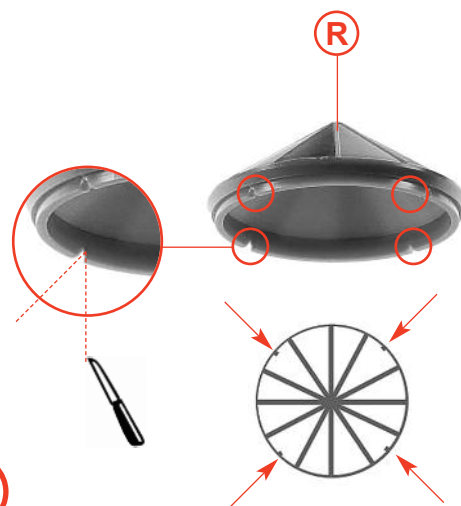
R**S**

3/4

S**T**2 x
250 mm

| | | | | | |
|---------|--------|----------|-------|--------|--------|
| Inhalt | Tüte | Contents | bag | silber | silver |
| Contenu | sachet | Inhoud | zakje | argent | zilver |

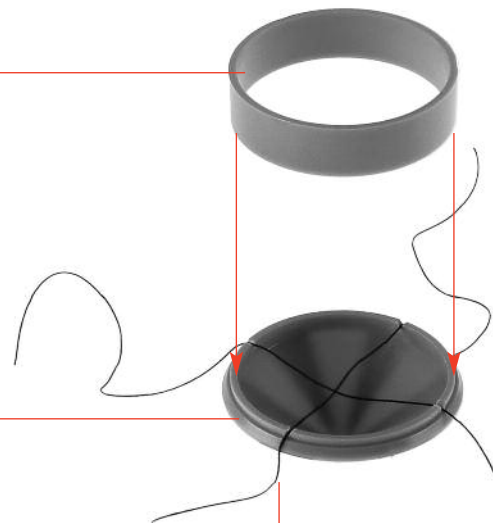

Deco 17

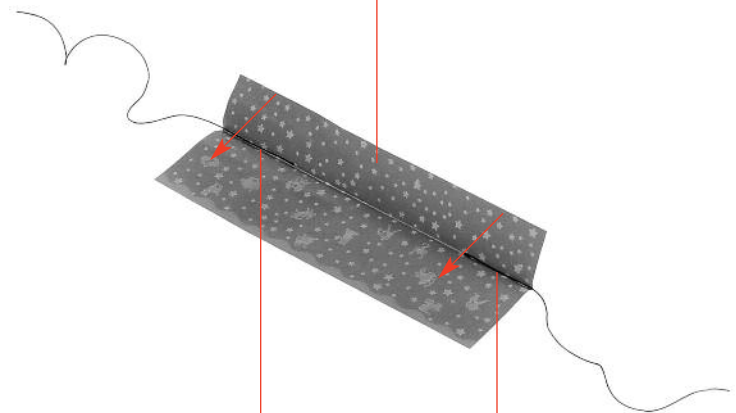

U

2 x
100 mm

| | | | | | |
|----------------|--------|-----------------|-------|------|-------|
| Inhalt | Tüte | Contents | bag | weiß | white |
| Contenu | sachet | Inhoud | zakje | banc | wit |

V

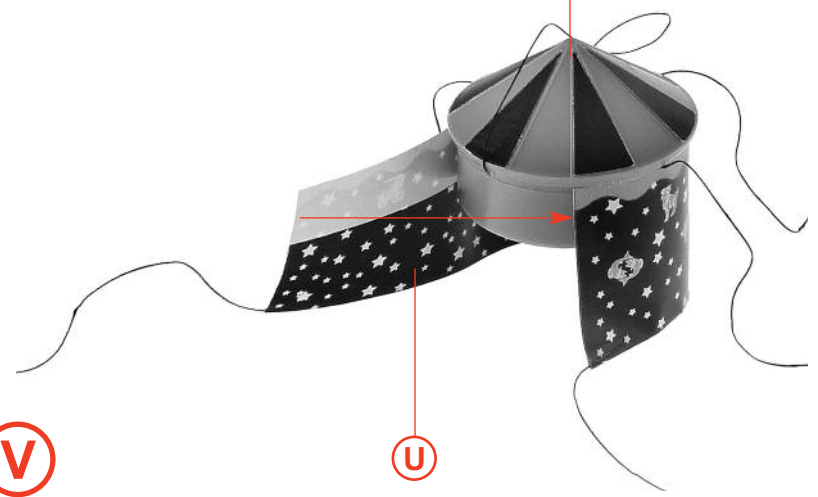

U

T

Mit Alleskleber kleben
 Use all-purpose glue
 Utiliser de la colle universelle
 Met een universele lijm lijmen

V

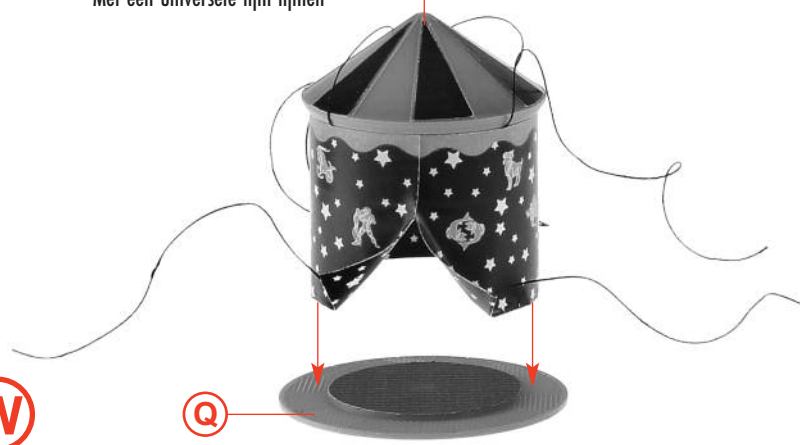

W

Q

Faden verknoten und den Knoten
 mit Sekundenkleber fixieren!

Knot the thread and fix the knot
 with instant cement!

Nouer le fil et renforcer le noeud
 avec une goutte de colle rapide!

Garen vastknopen en de knoop met
 secondenlijm fixeren!

3/11

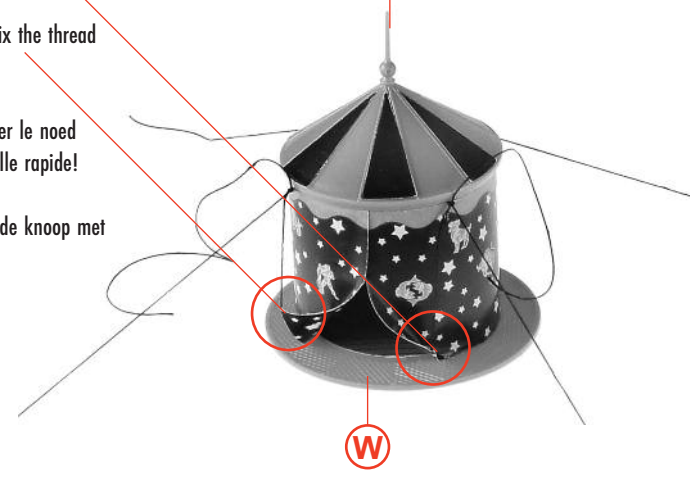

X

W

8

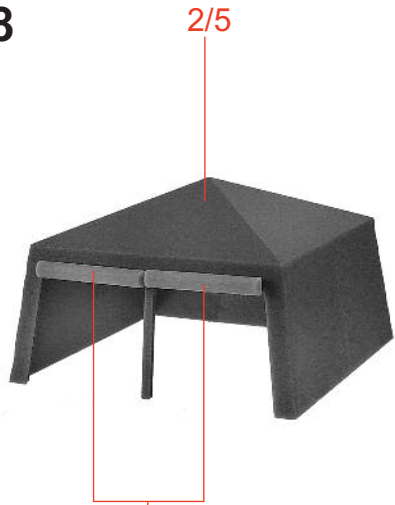

a

2/6

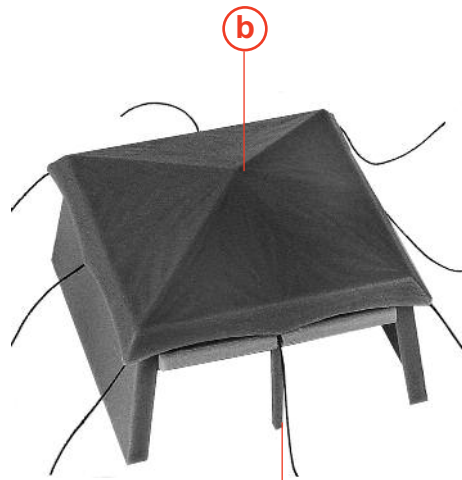

c

a

b

| Inhalt | Tüte | Contents | bag |
|---------|--------|----------|-------|
| Contenu | sachet | Inhoud | zakje |

8 x 100 mm

weiß white
blanc wit

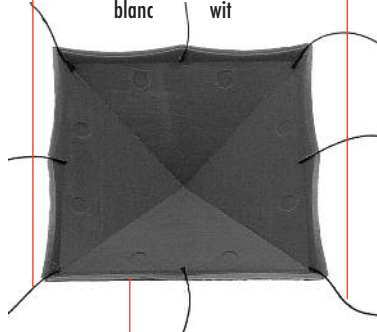

b

3/2 A



d

c

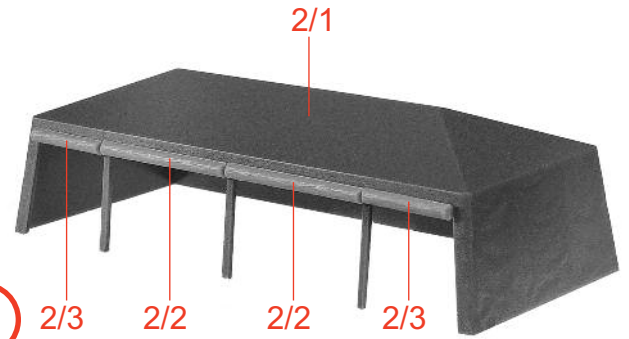

e

2/3

2/2

2/2

2/3

2/1

| Inhalt | Tüte |
|----------|--------|
| Contents | bag |
| Contenu | sachet |
| Inhoud | zakje |

14 x 100 mm

weiß white
blanc wit

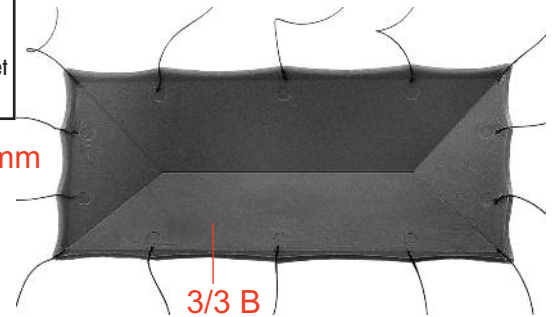

f

3/3 B

2/4

g

e

f

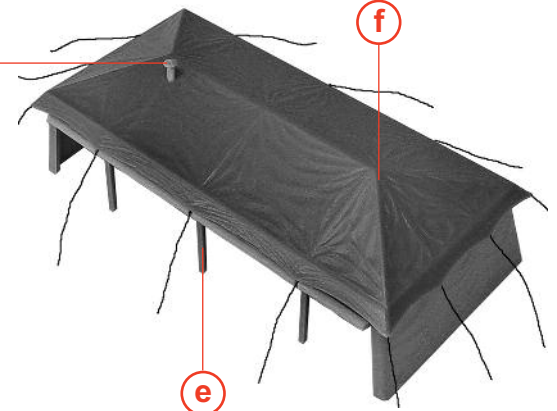

10

Deco 20



2/2

m

Deco 18

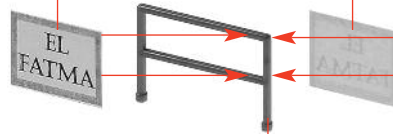
**n** 4 x**n****n****o** 2 x

2/12

m**p****o****o****q****p**

Deco 13

Deco 8

Deco 13

**r**

2/1

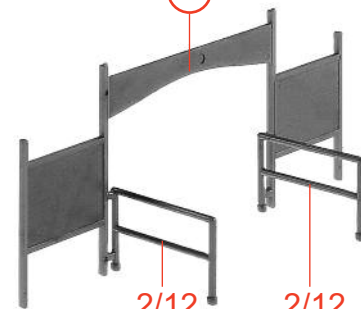
r**s**

2/12

2/12

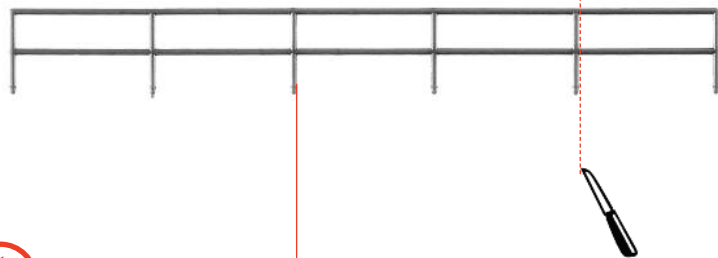
**t**

2/5

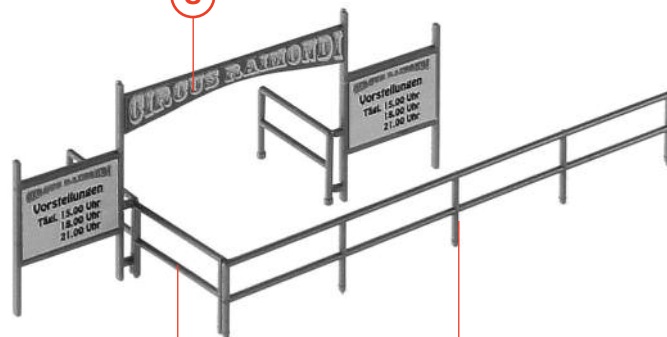
s**u**

2/9

t

Fensterfolie

Die beiliegende Fensterfolie entsprechend der benötigten Größe ausschneiden und vorsichtig mit wenig Klebstoff auf die Rückseite der Fensterrahmen aufkleben.

Window foil

Cut the attached window foil according the illustrations and glue it carefully with a little glue to the rear side of the window frames.

Feuillet transparent pour fenêtres

Découper le feuillet transparent pour fenêtres inclus d'après l'illustration. Coller proprement avec un peu de colle sur la face arrière du cadre des fenêtres.

Vensterfolie

De meegeleverde vensterfolie conform de afbeeldingen uitknippen of uitsnijden en voorzichtig met een beetje lijm op de achterzijde van het raam plakken.

8/16

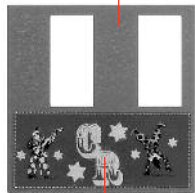

Deco 10



Fensterfolie 18,3 x 13,6 mm
Window foil
Feuillet transparent
Vensterfolie



M 1:1

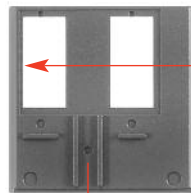

W

X

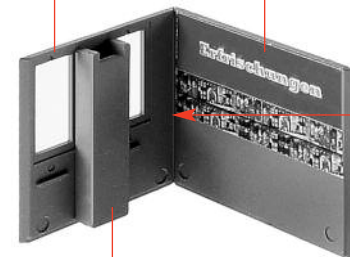

Deco 16



8/14



0,5 mm

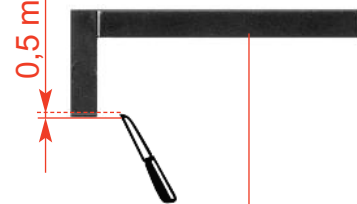

7/9



8/18

Y

12

8/15

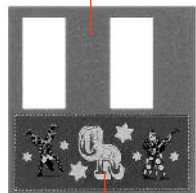

Deco 9

(A)

Fensterfolie 18,3 x 13,6 mm
Window foil
Feuillet transparent
Vensterfolie

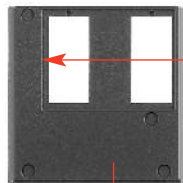

M 1:1

(B)

(A)

8/13

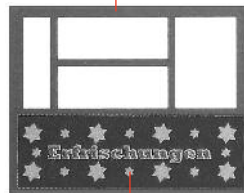

Deco 11

(C)

Fensterfolie 13,6 x 28,7 mm
Window foil
Feuillet transparent
Vensterfolie

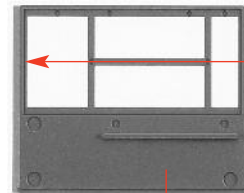

M 1:1

(D)

(C)

8/17

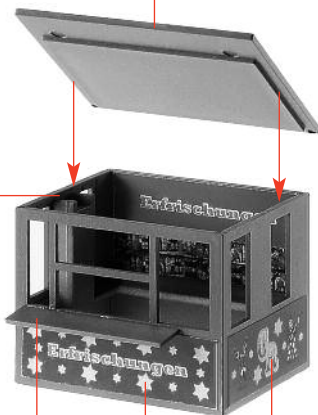

(Z)

7/13

(D)

(B)

(E)

8/4



Deco 12

(F)



M 1:1

(G)

(F)

Fensterfolie
14,3/13,4 x 14 mm
Window foil
Feuillet transparent
Vensterfolie

8/7



Deco 14

(H)



M 1:1

(I)

(H)

Fensterfolie
11,9/11 x 13 mm
Window foil
Feuillet transparent
Vensterfolie

8/6



Deco 14

J

Fensterfolie 11,9/11 x 13 mm
Window foil
Feuillet transparent
Vensterfolie

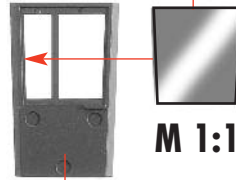

M 1:1

K

J

8/5



Deco 12

L

Fensterfolie 14,3/13,4 x 13,3 mm
Window foil
Feuillet transparent
Vensterfolie

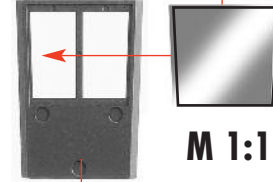

M 1:1

M

L

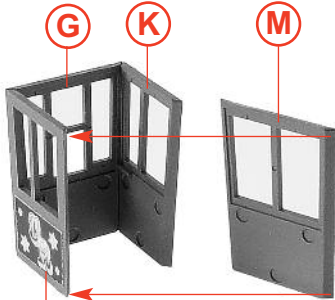

N

I

7/6

KASSE



Bemalungshinweis, rot
Painting instruction, red
Instruction de coloration, rouge
Schilderadviezen, rood

O

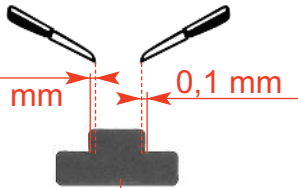

P

7/8

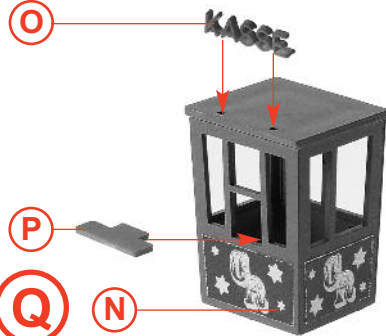

Q

N

E

Q

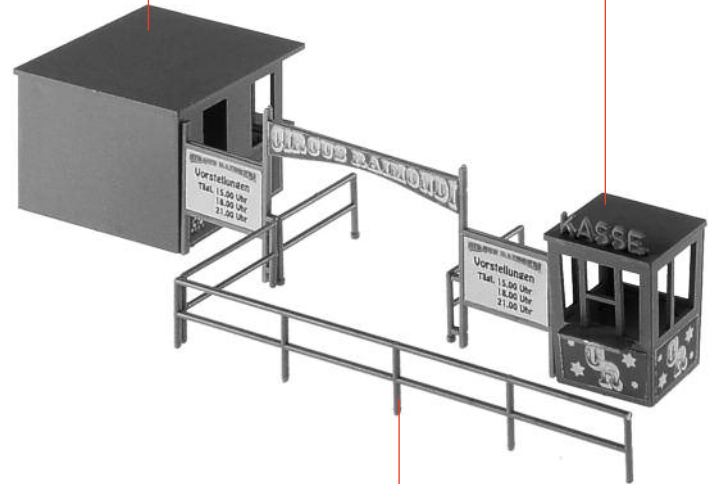

R

u

14

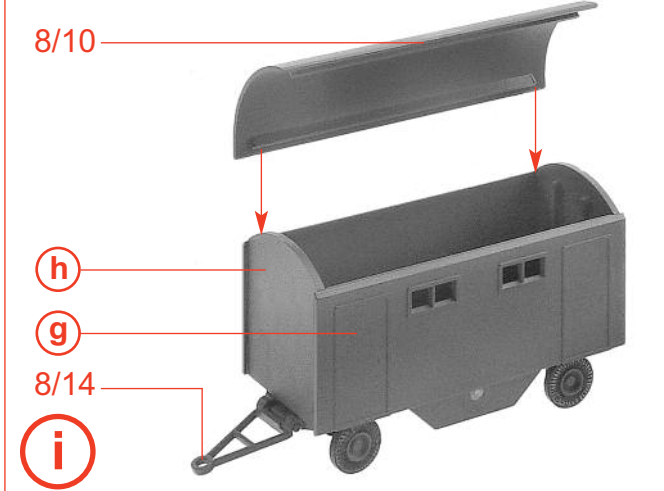
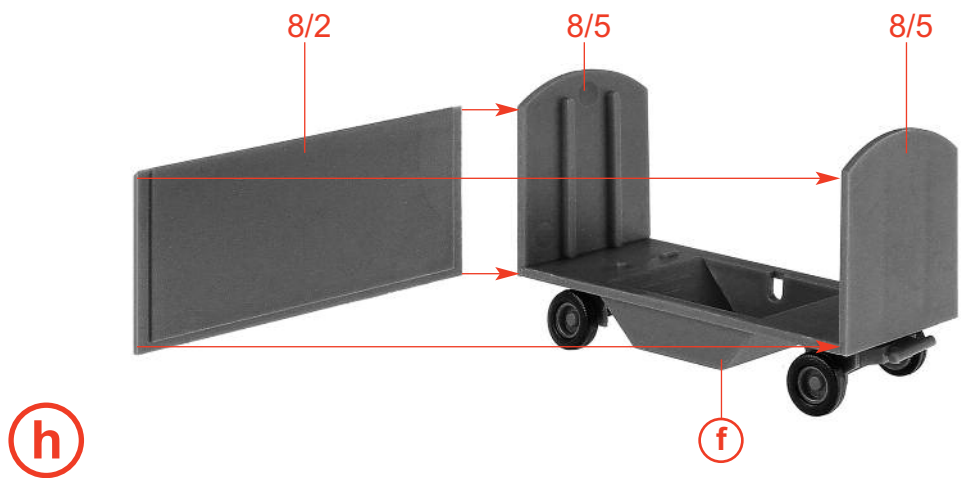
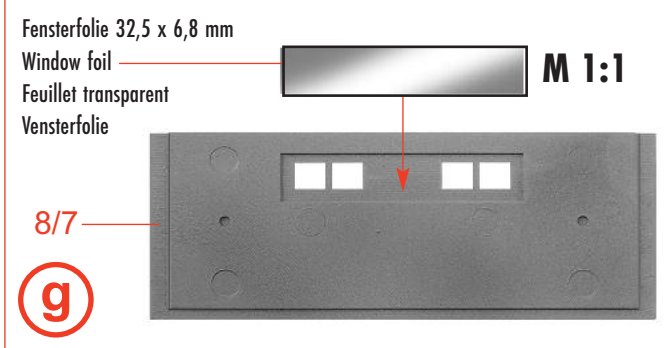
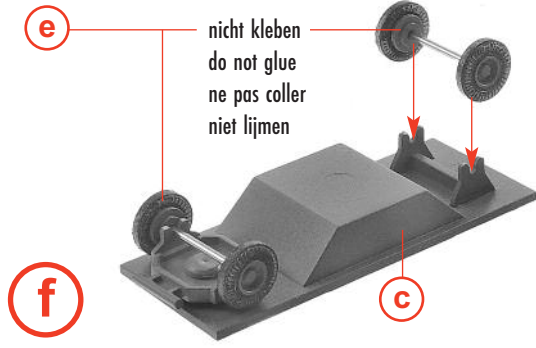
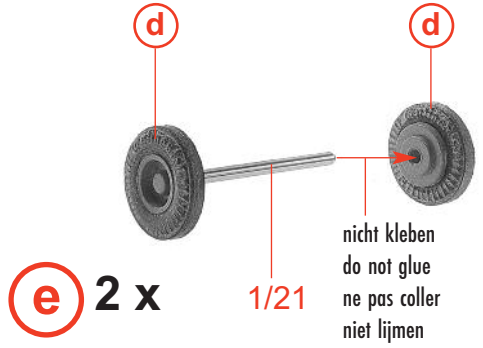
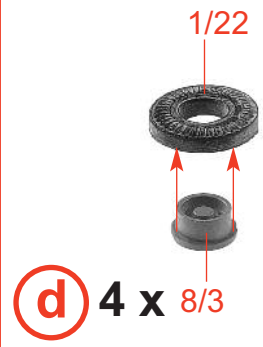
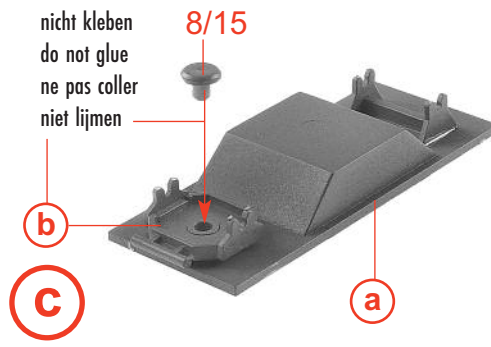
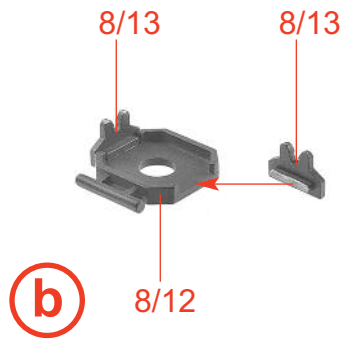
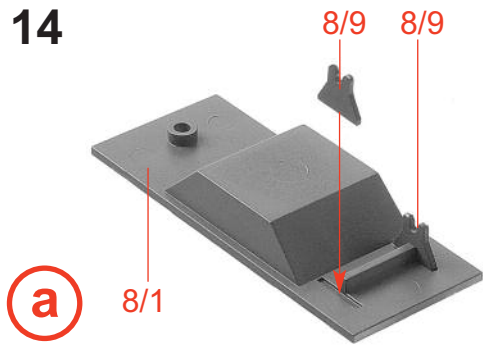

Papiermaske
Papermask
Masque
Masker **M3**

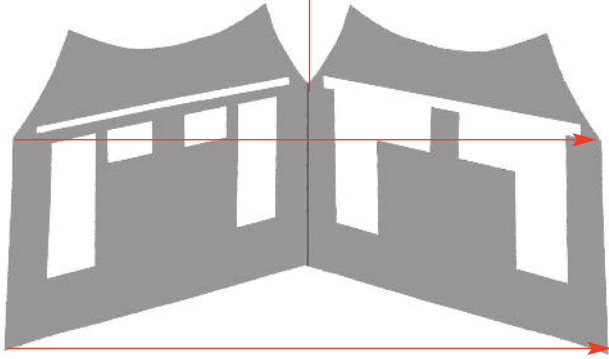

j

j



k

Deco 1

Deco 2

15

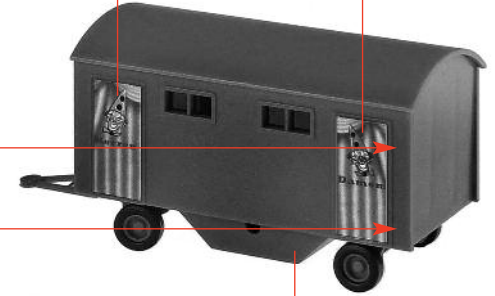

i

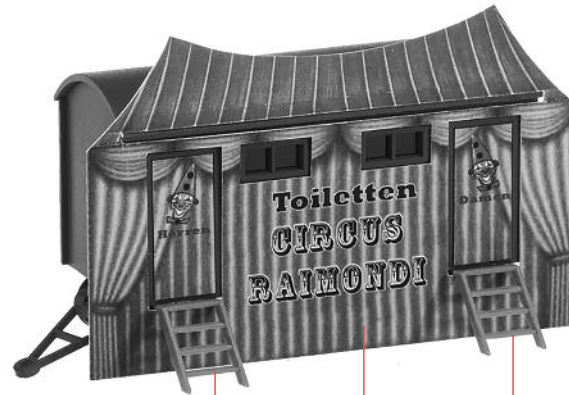

4/8

k

4/8

l

16

Fensterfolie 8 x 6,8 mm
Window foil
Feuillet transparent
Vensterfolie

8 x 5 mm

8 x 6,8 mm

M 1:1

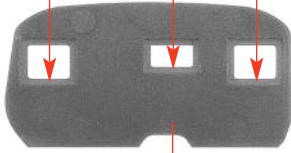

1/2

m

Fensterfolie 8 x 6,8 mm
Window foil
Feuillet transparent
Vensterfolie

8 x 6,8 mm

M 1:1

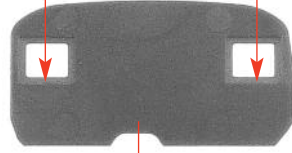

1/3

n

Fensterfolie 18 x 8 mm
Window foil
Feuillet transparent
Vensterfolie

M 1:1

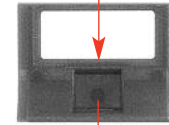

1/5

o

Fensterfolie 18 x 8 mm
Window foil
Feuillet transparent
Vensterfolie

M 1:1

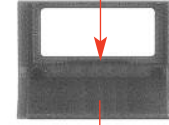

1/4

p

m

n

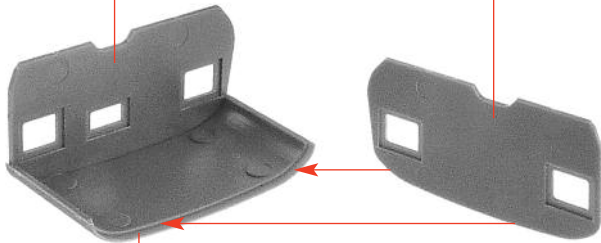

1/1

q

Papiermaske
Papermask
Masque
Masker **M4**

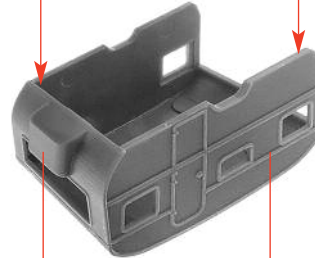
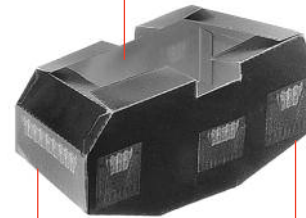

r

o

q

r

p

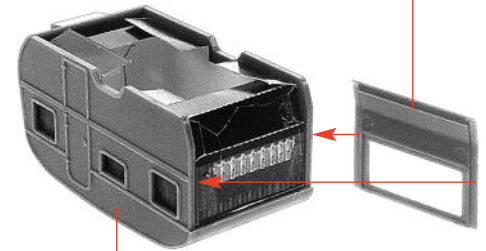

r

s

Fensterfolie 13 x 8 mm
Window foil
Feuillet transparent
Vensterfolie
M 1:1



1/7

t

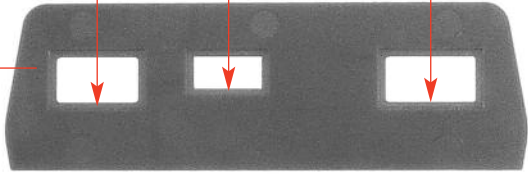

Fensterfolie 19 x 8 mm
Window foil
Feuillet transparent
Vensterfolie
M 1:1



1/10

u

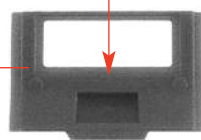

Fensterfolie 14 x 8 mm
Window foil
Feuillet transparent
Vensterfolie
M 1:1



1/8

v

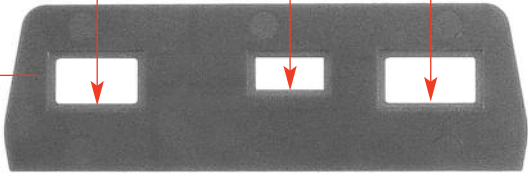

Fensterfolie 19 x 8 mm
Window foil
Feuillet transparent
Vensterfolie
M 1:1



1/9

w

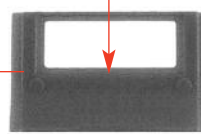

Papiermaske
Papermask
Masque
Masker **M5**

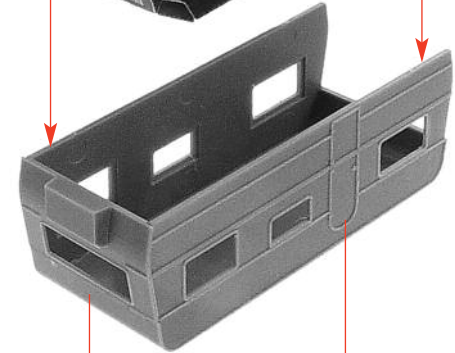
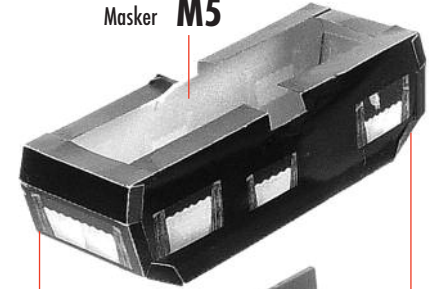

y

u

x

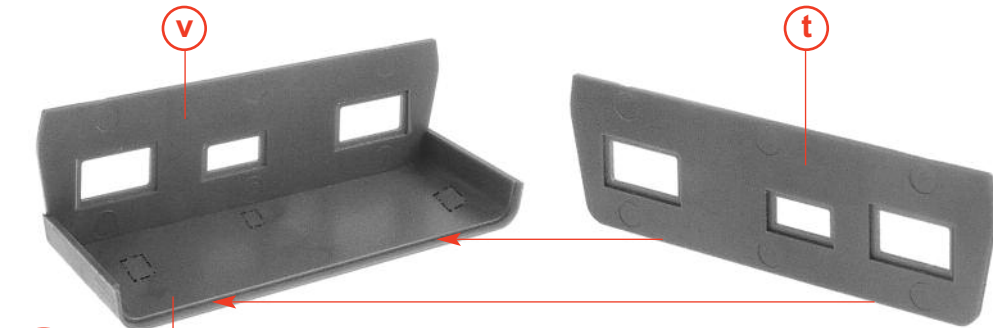

x

1/6

t

z

y

w

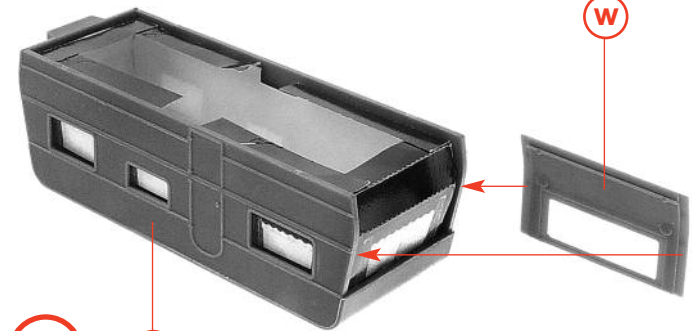

18

1/13

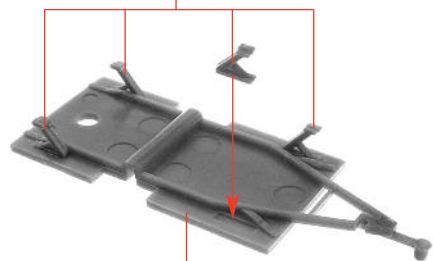

(A)

1/11

1/14

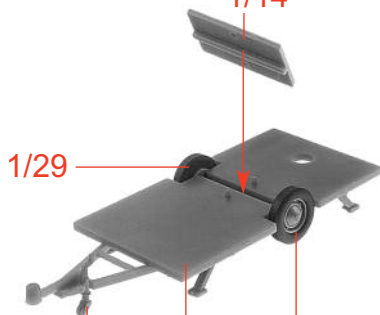

(B)

1/16

(A)

1/29

(B)

Art.-Nr. 180671 liegt nicht bei
not included
non jointe
niet bijgevoegd

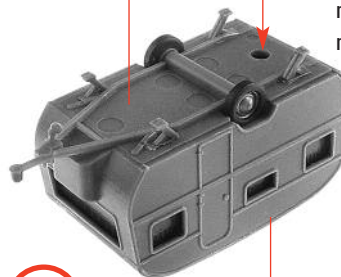

(C)

(S)



(D)

(C)

1/13

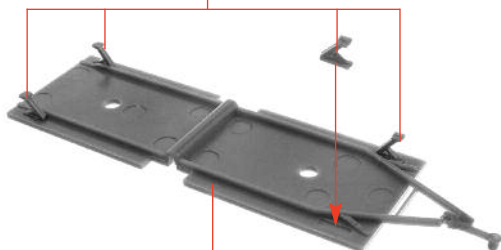

(E)

1/12

1/15

1/29

(F)

1/16

(E)

1/29

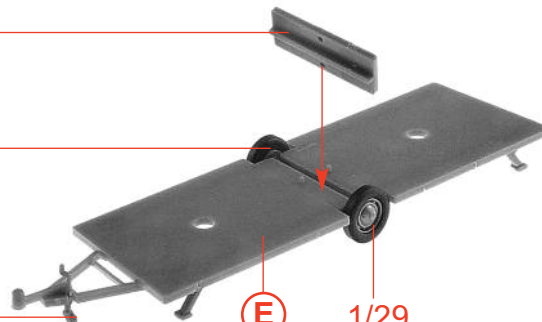

Art.-Nr. 180671 liegt nicht bei
not included
non jointe
niet bijgevoegd

(F)

(Z)

(G)

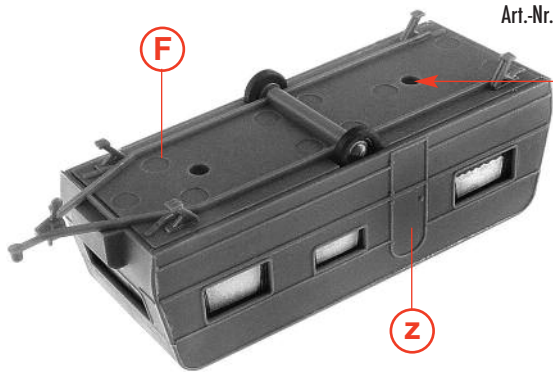

(H)

(G)

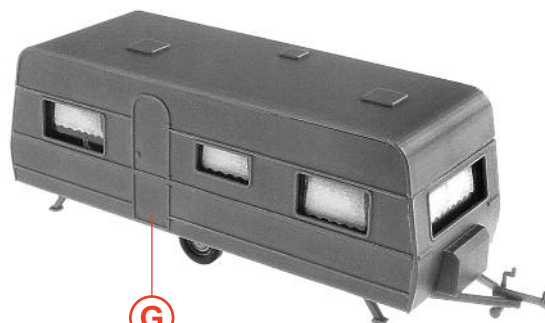

| | |
|-----------------|--------|
| Inhalt | Tüte |
| Contents | bag |
| Contenu | sachet |
| Inhoud | zakje |

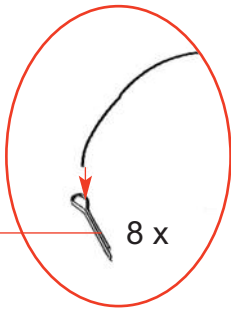

Faden verknoten und den Knoten mit Sekundenkleber fixieren!

Knot the thread and fix the thread with instant cement!

Nouer le fil et renforcer le noeud avec une goutte de colle rapide!

Garen vastknopen en de knoop met secondelijm fixeren!

P

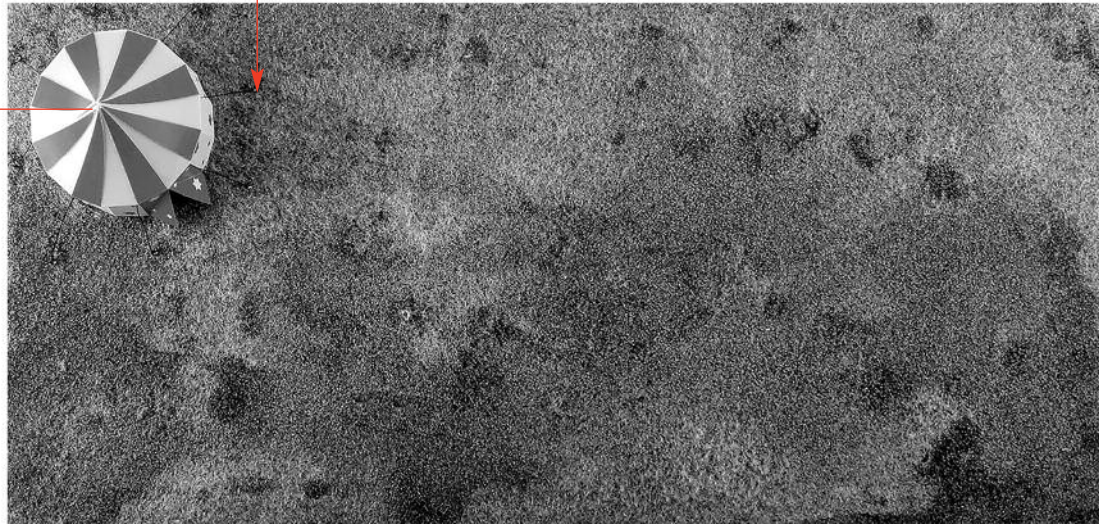

I

20 21/5 Deco 21 21/5 21/5 Deco 22

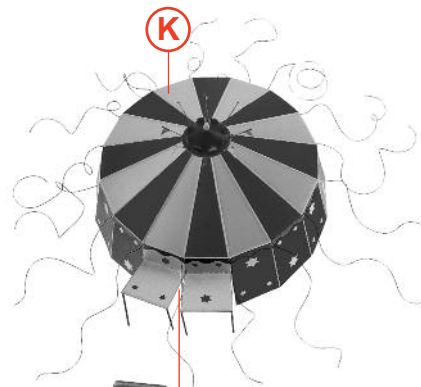
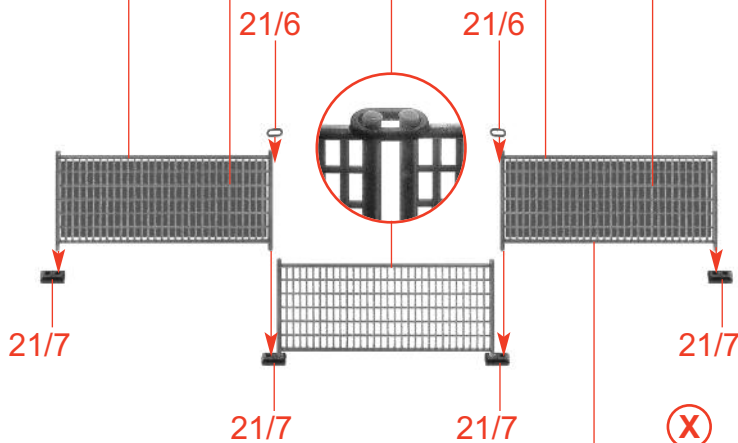

| | | | |
|---------|--------|----------|-------|
| Inhalt | Tüte | Contents | bag |
| Contenu | sachet | Inhoud | zakje |

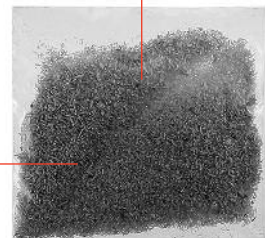

21/7

21/7

21/7

21/7

48 x

X

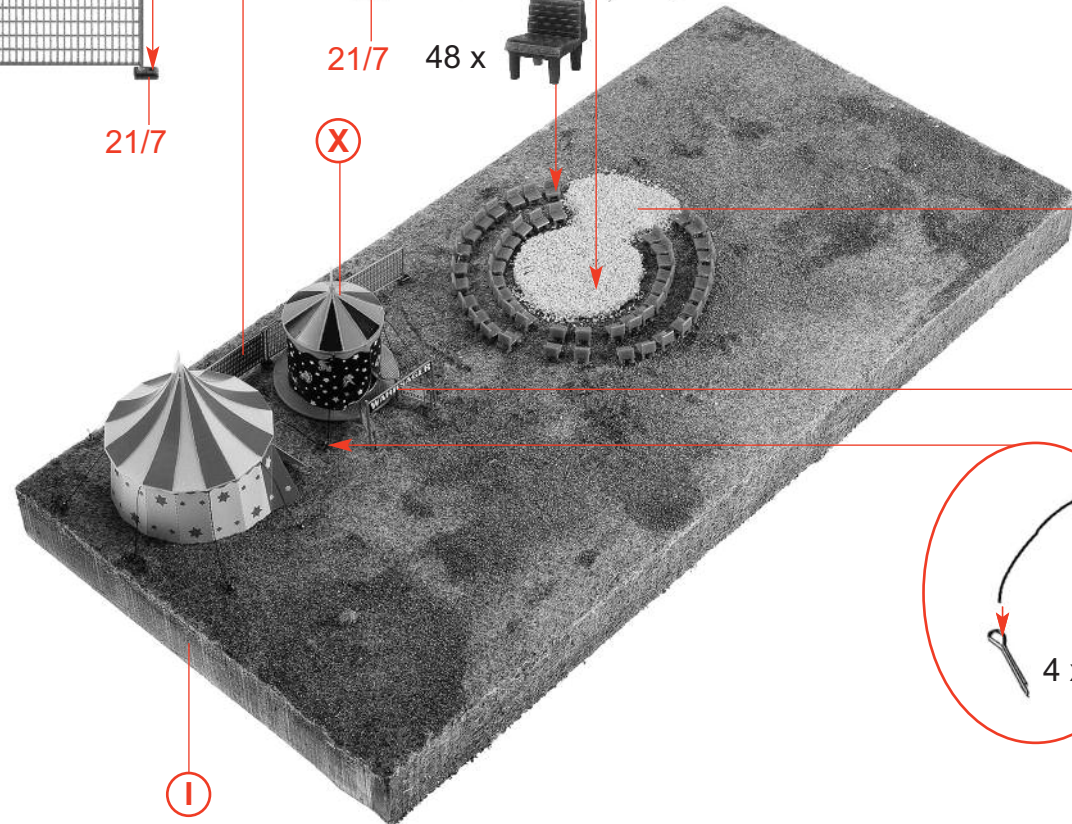

q

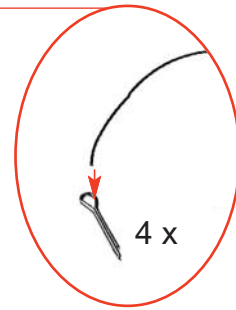

4 x

| | |
|----------|--------|
| Inhalt | Tüte |
| Contents | bag |
| Contenu | sachet |
| Inhoud | zakje |

J

I

| | | | |
|---------|--------|----------|-------|
| Inhalt | Tüte | Contents | bag |
| Contenu | sachet | Inhoud | zakje |

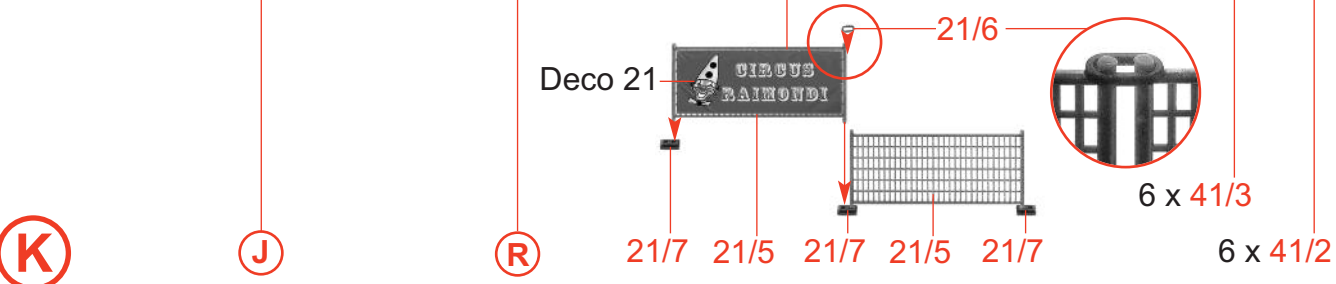
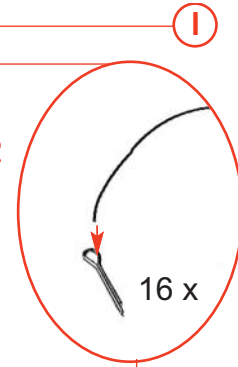
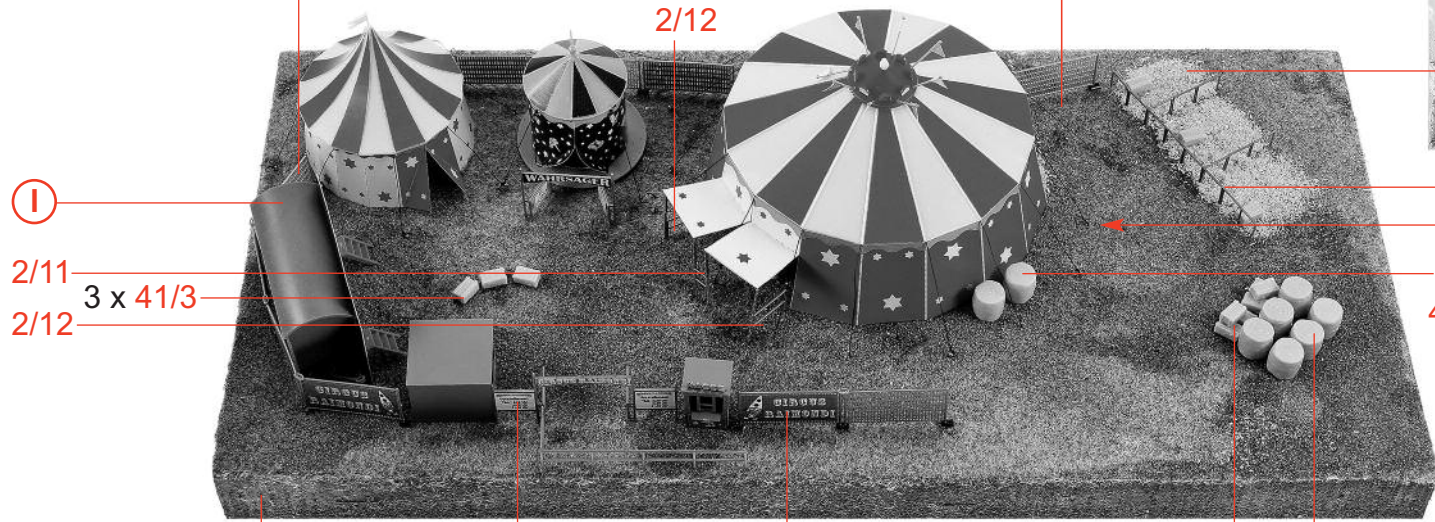
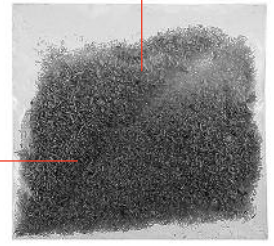
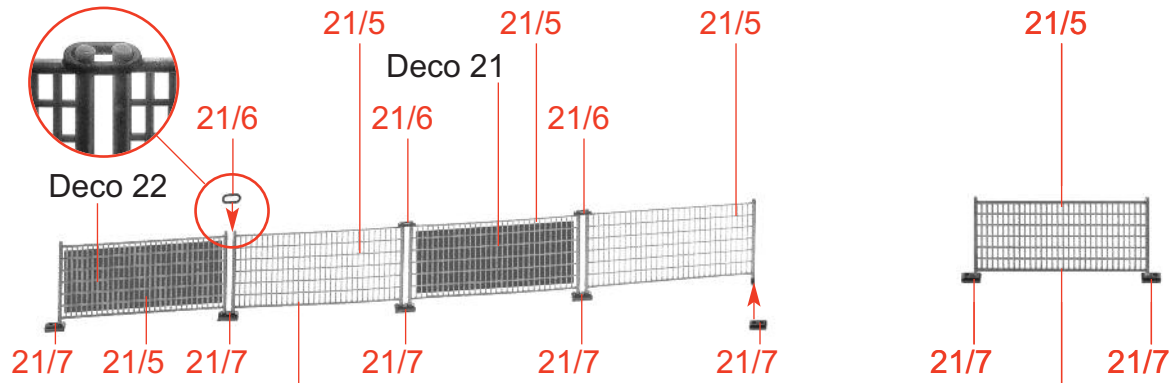

| | |
|----------|--------|
| Inhalt | Tüte |
| Contents | bag |
| Contenu | sachet |
| Inhoud | zakje |

K

J

R

I

g



| | |
|----------|--------|
| Inhalt | Tüte |
| Contents | bag |
| Contenu | sachet |
| Inhoud | zakje |

L

K

d

22 x

| | | | |
|---------|--------|----------|-------|
| Inhalt | Tüte | Contents | bag |
| Contenu | sachet | Inhoud | zakje |

| | | | |
|---------|--------|----------|-------|
| Inhalt | Tüte | Contents | bag |
| Contenu | sachet | Inhoud | zakje |

21/5 Deco 22

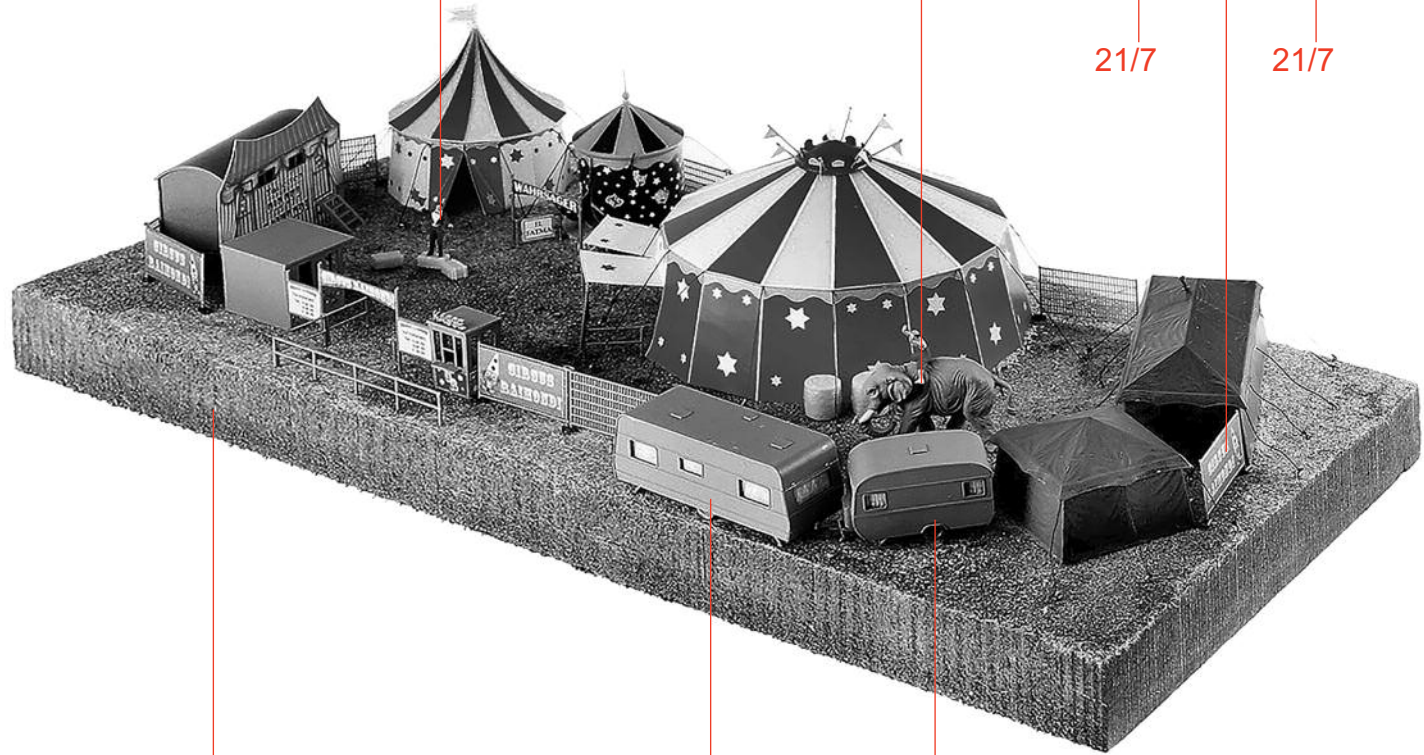

21/7

21/7

M

L

H

D

